

HELISTAR

EUSF-□□

單法蘭式電磁離合器. 制動器組合

Single flange type clutch & brake unit

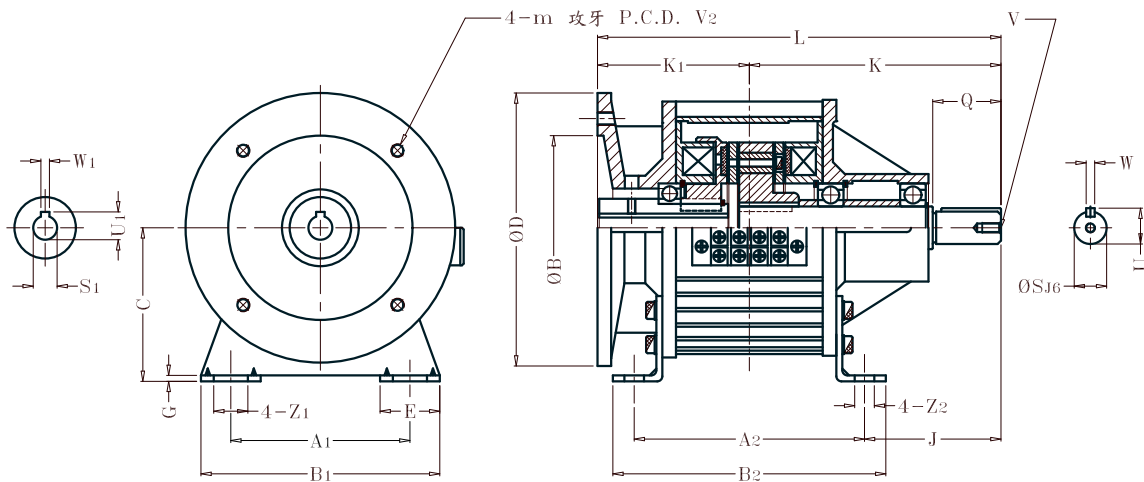

| 型號Model | 0.6 | 1.5 | 2.5 | 5 | 10 | 20 | |
|---------------|-------|-----------|-----------|-----------|-----------|----------|------------|
| 本體 (Body) | A1 | 65 | 80 | 105 | 135 | 155 | 195 |
| | A2 | 90 | 110 | 135 | 160 | 200 | 240 |
| | B | 95 | 95 110 | 110 130 | 130 | 180 | 230 |
| | B1 | 90 | 110 | 140 | 175 | 200 | 240 |
| | B2 | 105 | 130 | 160 | 185 | 230 | 270 |
| | C | 65 | 80 | 90 | 112 | 132 | 160 |
| | D | 140 | 140 160 | 160 200 | 200 | 250 | 300 |
| | G | 2.6 | 3.5 | 3.5 | 4.5 | 6 | 20 |
| | J | 48.5 | 63 | 80 | 108 | 145 | 188 |
| | K | 93.5 | 118 | 147.5 | 188 | 245 | 308 |
| | K1 | 64.5 | 79 | 89 | 105 | 138 | 160 |
| | L | 158 | 197 | 236.5 | 293 | 383 | 468 |
| | m | M8 | M8 | M8 M10 | M10 | M12 | M12 |
| | V | M4*0.7深8 | M4*0.7深8 | M6*1深11 | M6*1深11 | M6*1深11 | M10*1.5深17 |
| | V2 | 115 | 115 130 | 130 165 | 165 | 215 | 265 |
| | Z1 | 13.5 | 15 | 20 | 24 | 28 | 28 |
| Z2 | 6.5 | 9 | 11 | 11 | 14 | 14 | |
| 軸部 (Shaft) | Q | 25 | 30 | 40 | 50 | 60 | 80 |
| | S | 11 | 14 | 19 | 24 | 28 | 38 |
| | S1 | 11 | 11 14 | 14 19 | 19 24 | 28 | 38 |
| | U | 12.5 | 16 | 21 | 27 | 31 | 41.5 |
| | U1 | 12.5 | 12.5 16 | 16 21.5 | 21.5 27 | 31 | 41 |
| | W | 4 | 5 | 5 | 7 | 7 | 10 |
| W1 | 4 | 4 5 | 5 6 | 6 8 | 8 | 10 | |
| 配合電機(4P) | 1/4HP | 1/4~1/2HP | 1/2~1HP | 1~2HP | 3~5HP | 7.5~10HP | |